

## DM650PM USER GUIDE

### DM650PM BATTERY POWERED DIGITAL PRESSURE DISPLAY WITH RELAY AND NFC INTERFACE LOGGING FUNCTION USER GUIDE

**Important - Please read this document before installing.**

Every effort has been taken to ensure the accuracy of this document; however, we do not accept responsibility for damage, injury, loss or expense resulting from errors and omissions, and we reserve the right of amendment without notice.

#### IMPORTANT – CE, UKCA & SAFETY REQUIREMENTS.

The instrument is designed to be either directly attached to a sensor probe assembly or surface mounted. The user must ensure all sensor and cable entries maintain environmental protection to at least IP65 rating.

Battery - Fire Explosion and Severe Burn Hazard. Do not attempt to re-charge, Crush, Incinerate, Disassemble, Heat above 100 °C (212 °F) or expose to water.

**Disposal of the battery must conform with the regulations applicable for the area of use.**

The product contains no serviceable parts, or internal adjustments. No attempt must be made to repair this product. Faulty units must be returned to supplier for repair. This product must be installed by a qualified person. All electrical wiring must be carried out in accordance with the appropriate regulations for the place of installation. Before attempting any electrical connection work, please ensure the battery is removed

ABSOLUTE MAXIMUM CONDITIONS: To exceed may cause damage to the device.	
Battery voltage	3.7 Vdc (Protected for reverse connection)
Relay	50 Vdc, 40 Vac rms
Ambient	Temperature (-30 to 70) °C, Humidity (10 to 95) % RH noncondensing)
Overpressure	Range specific refer to datasheet



**Important – Read this document before installing.**

#### 1~DESCRIPTION.

DM650PM battery powered indicator accepts gauge or absolute pressure and displays the sensor pressure in bar, PSI or the user's engineering unit on a 6-digit LCD display. The instrument offers an advanced display mode allowing the user to also display one or two (1 to 32) character messages. Additional to the messages, the user may select an alert-event to occur when the pressure is within a band. A change-over relay can be used together with the messaging and alerts to provide switching at user-set points. In addition to this, on-board datalogging is also available to record process details at up to 5000 points.

#### 2~RECEIVING AND UNPACKING.

Please inspect the packaging and instrument thoroughly for any signs of transit damage. If the instrument has been damaged, please notify your supplier immediately.

#### 3~SPECIFICATION.

Configuration : Refer to data sheet for full specification.	
Factory default	Display unit = bar, relay off, LED off

#### 4~ INSTALLATION AND WIRING.

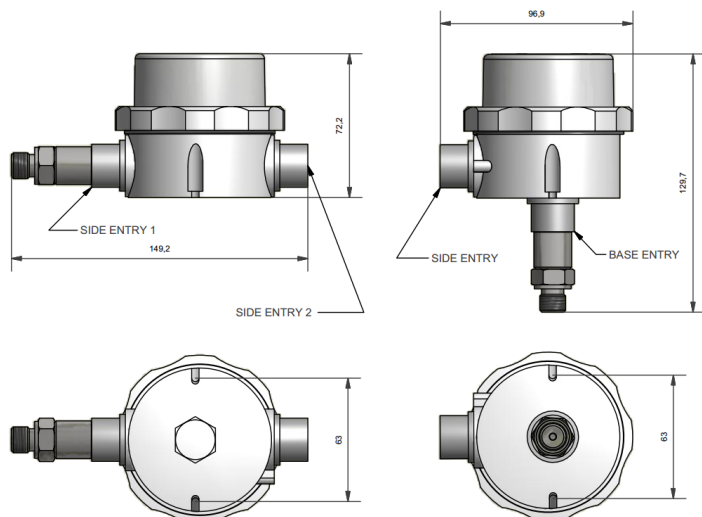

#### 4.1~MECHANICAL.

The instrument is a high accuracy, digital pressure, battery powered, display. In order to ensure correct operation, the following must be observed:

The product must be stored in a dry clean environment and remain in original packaging prior to installation.

The instrument must not be installed adjacent to electro-mechanical starters, controllers, thyristor power units or electrical switch gear.

Any cleaning of the instrument must be done using a mild detergent and soft cloth. No solvents or abrasive cleaners should be used.

Stated ambient operating conditions must not be exceeded. Battery life will reduce with higher ambient temperature operating conditions.

#### 4.2~ELECTRICAL.

**For a wiring diagram please refer to the rear panel of the DM650PM inside the case housing.**

A two-part connector is used for the relay connections and a pluggable ribbon cable connector for the sensor, allowing the unit to be easily removed from the housing for reprogramming or data download if this is not possible in situ. On insertion of battery the unit will run through a power-up check; during this time the relay may change state.

**IMPORTANT:** Always remove battery before any wiring takes place. Gain access to the connectors and battery holder by twisting cap ring to release front panel assembly from case.

**RELAY CONNECTION:** A relay with changeover contacts is available. Screw terminals are provided for connection for wire size 16 to 20 AWG. The relay contacts are rated at 48 VDC, 28 VAC RMS @ 1 A (5 mA minimum current) see DM650PM data sheet. The relay connections are marked "NO" for normally open, "NC" for normally closed and "C" for common.

**BATTERY:** To remove battery, use screwdriver to ease the positive end of the battery out of holder. Insert new battery negative end first then press into place. (Observe polarity). Battery type 3.6 V Lithium (2.4 A/Hr) CR14505 (IEC) AA case style. Please dispose of the battery in a responsible way.

#### WARNING

For configuring, reading live data or reading logged data if using a grounded sensor on the input, it is important not to connect the programming USB lead to a mains-powered computer. It is possible to damage the instrument if connected in this way.

To avoid damage, use one of the following methods:

- Ensure any sensor connected and DM650 housing are not in contact with any conductive parts during configuration.
- Use a laptop-type computer running from its battery power supply, not connected to a mains supply. This is recommended for reading lived data or offsetting a unit if already installed in the field.
- Use a USB isolator between the computer and the DM650.

#### 5~USER CONFIGURATION.

**IMPORTANT READ COMPLETE SECTION BEFORE ATTEMPTING CONFIGURATION.**

The instrument is provided with a USB interface for direct connection to a PC. Free software USBSpeedLink is available. Please refer to the USBSpeedLink software for further information on configuration. The software can be downloaded from [www.status.co.uk](http://www.status.co.uk).

**DISPLAY:** The display provides six 14-segment characters for display of temperature and alpha-numeric messages, together with an 8-segment bar graph and six icons. The display can operate in an ambient temperature range of (-30 to 70) °C, but at temperatures lower than -5 °C (due to the slower LCD speed) scrolled messaging is not practical for screen updates.

The display's high contrast, coupled with a digit height of 7.9 mm, offers clear readouts at low as well as high ambient light and direct sunlight.

The display layout is as follows:

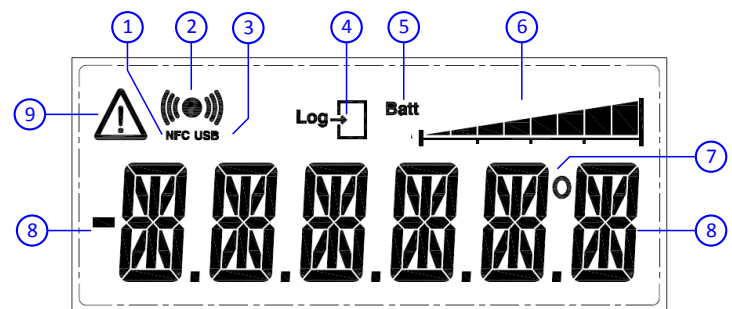

## 5~USER CONFIGURATION (continued).

- NFC - The Symbol is on when an NFC field is detected. When a detected field is lost the symbol will turn off after a few seconds.
- TRANSMIT/RECEIVE: Symbol on when either NFC or USB communication is active.
- USB: Symbol on when USB port is connected to a PC. Please note battery is not required during configuration.
- LOG: Not used
- Batt: On when battery voltage is low.
- BAR GRAPH: Indicates the state of the logger. The condition is dependent on the selected logger mode, either Single or Rolling mode.

Single Mode (Log to the maximum number of logs then stop)

Start of Log      Mid Log      End of Log (alternating)

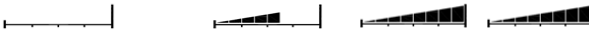

Rolling Mode (Log to the maximum number of logs then as each new log is taken the oldest log is discarded)

Start of Log      Mid Log      Rolled over Log (max bar toggles)

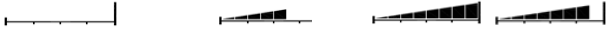

- DEG: Degree symbol "°" used to indicate either °C, °F on the last digit when the temperature display option is selected with the main process value display.
- DIGITS: Six-digit 14-segment display with - sign, range 9999.9 to -9999.9. Advanced mode offers two process value-dependent 32-character message options.
- WARNING ICON: This symbol will toggle on and off to indicate a warning. The warning symbol will be active either when the sensor signal is out of range, not connected or when the battery is low



### MULTI-FUNCTION ALERT LED

The alert LED normal state is off, on alert the LED will emit a intense white light pulse every 5 seconds. The LED can be programmed to pulse on any of the following combined events:

Mode	Description
No events	The LED never operates, extending battery life. (Factory default setting)
Battery	Alert on low battery detect.
Trip	Alert when relay 1 trip is on.
Process	In advanced mode only the alert LED can be made to alert in any one of eight user-set process value bands. Example, to alert operator when process value is outside a safe operating range. The function of the alert LED can be further enhanced with the option of displaying an alert message in advanced display mode.



### NFC LOGGER INTERFACE

The NFC interface allows the instrument to communicate with an Android device using NFC connectivity.

The prime function of the interface is to read logged data from the device using a free app, which is available for downloading to Android devices.

The app allows the user to read existing logs, change the log manifest, start a new log, synchronise the instrument clock and reset the maximum/minimum/average readings. Logs can run to a fixed number and stop or continually roll over, up to 5000 log points can be recorded. The start of the log can be delayed up to one month.

Note: For larger logs the data may take over a minute to fully download via the NFC interface.

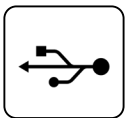

### USB LOGGER INTERFACE (connector inside housing)

The USB interface allows the instrument to communicate with a PC running the USBLogLink software

The prime function of the interface is to read logged data from the device using free software available to download.

The software allows the user to read existing logs, change the log manifest, start a new log, synchronise the instrument clock and reset the maximum/minimum readings.

USBLogLink is available from the manufacturer or supplier.

## USBLogLink DATA LOGGER SOFTWARE\*

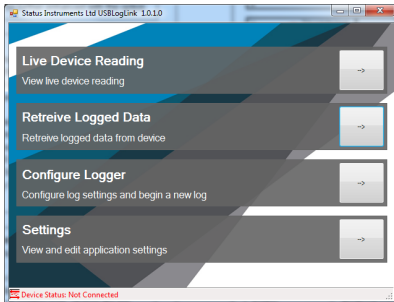

### LIVE DEVICE READING TAB

Display      Live process value, Pressure (scaled) and Temperature

### RETRIEVE LOGGED DATA TAB

Download and graph recorded logged data, Pressure (scaled), Relay condition

### CONFIGURE LOGGER

Set new log (rolling or fixed), interval time, number of logs, delay start

Enter (tag and contact), Reset (max and min) Sync clock

## USBSpeedLink CONFIGURATION SOFTWARE\*

### TRANSDUCER OPTIONS TAB

Select      User-calibration functions, Pre-set input value.

**When the DM650PM is first connected allow the software to do an auto read to establish the sensor range.**

Pre-set Sensor Signal to Set-Point the input value can be fixed to a pre-determined value. The messaging display and relay will respond accordingly.

### PROCESS SCALING TAB

Select      Engineering units, range, user-linearisation table, decimal place, null least significant digit(s) if required.

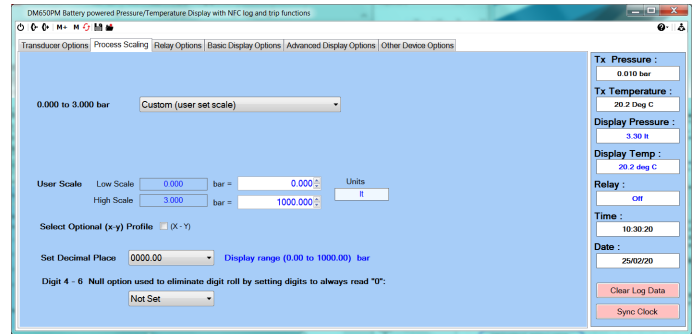

### RELAY OPTIONS TAB

Select      Select relay operation, set-point, dead band, relay name  
A low battery relay alarm can also be set

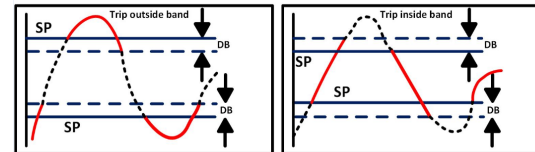
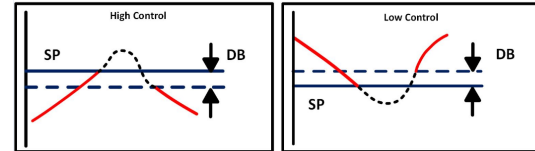
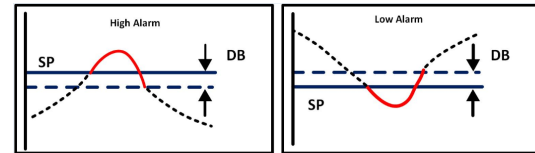

### BASIC DISPLAY OPTIONS TAB

Select      Display options pressure/units/temperature (°C, °F)  
Update rate,  
LED alert for battery, relay

### ADVANCED DISPLAY OPTIONS TAB

Select      Message bands, custom messages  
Use this software tab to set up advanced scrolling user-messaging

### OTHER DEVICE OPTIONS TAB

Enter      Tag, contact details  
Enter      Android passkey (protect logged data)  
Enter      Device location  
Read/clear      Maximum and minimum reading  
Synchronise      Clock

\*Logging and configuration software can be downloaded from [www.status.co.uk](http://www.status.co.uk)



Status Instruments Ltd, Status Business Park, Gannaway Lane, Tewkesbury, Gloucestershire, UK, GL20 8FD

Web Page: [www.status.co.uk](http://www.status.co.uk), Email: [sales@status.co.uk](mailto:sales@status.co.uk)

Technical Support: [support@status.co.uk](mailto:support@status.co.uk)

Tel: +44 (0) 1684 296818, Fax: +44 (0) 1684 293746