



PID
AUTO TUNING
FUZZY LOGIC



PUR-49D

- ❑ ON-OFF hysteresis, Fuzzy PID, Auto-tuning
- ❑ dual LED display: PV - measured value
SV - setpoint value
- ❑ universal input: 0/4-20 mA, 0-10V, 0-150 mV, RTD or TC
- ❑ REL 5A / OC (SSR) outputs
- ❑ analogue output: active or passive, power supply output: 24V DC
- ❑ RS-485 / Modbus RTU in standard
- ❑ signal peak value detection
- ❑ free configuration software S-Config

PUR-49D is a simple two step controller (also known as ON-OFF or hysteresis controller) and, at the same time, an advanced PID controller with two control loops (heating / cooling), supported by the auto-tuning function and Fuzzy-Logic algorithm. The main advantages are two rows of display: the first one presents measuring value, second one - programmed values. The device has a build-in REL, OC (SSR) or analog output, according to the customer selection: active current output, passive isolated current output or active voltage output, which can be used in the process of control. The **PUR-49D** controller is equipped with one universal input, type: 0/4-20 mA, 0-10V, 0-150 mV, Pt 100/500/1000 or TC (K, S, J, T, N, R, B, E). During the measurement process only one kind of input is available. Cold junction of thermocouple sensor is compensated automatically. RTD and TC inputs feature with fully linearized characteristics. Thanks to wide range of characteristic curves (linear, square root, quadratic, user-defined and volume characteristic for cylindrical tanks) the controller may be used in various process control systems. The controller can be configured with the local keyboard or free S-Config software via the RS-485 communication port.

TECHNICAL DATA

Power supply	19V ÷ 50V DC; 16V ÷ 35V AC or 85 ÷ 260V AC/DC or 12V AC/DC, all separated
Power consumption	for 12V AC/DC, 85 ÷ 260V AC/DC and 16V ÷ 35V AC power supply: max. 7 VA; for 19V ÷ 50V DC power supply: max. 7 W
Display	LED, dual: 4 x 9 mm (PV) + 4 x 9 mm (SV), red/green or green/red
Displayed values	-999 ÷ 9999 + decimal point
Input	<u>current</u> : 0-20 mA or 4-20 mA, input resistance < 65 Ω (typ. 30 Ω), overload-protected, input current limited to 50 mA; <u>voltage</u> : 0-5 V, 1-5V, 0-10V or 2-10V, input resistance > 100 kΩ <u>milivoltage</u> : 0-60 mV, 0-75 mV, 0-100 mV, 0-150 mV, input resistance > 1,5 MΩ <u>thermoresistance</u> : Pt100, Pt500, Pt1000 (automatic recognition of 2, 3 and 4-conductor connection, resistance compensation of connecting conductors to 20 Ω at any conductor); measuring range: -100°C ÷ 600°C <u>thermocouple</u> : type K, S, J, T, N, R, B, E; measuring range: K: -200°C ÷ +1370°C; S: -50°C ÷ +1768°C; J: -210°C ÷ +1200°C; T: -200°C ÷ +400°C; N: -200°C ÷ +1300°C; R: -50°C ÷ +1768°C; B: +250°C ÷ +1820°C; E: -200°C ÷ +1000°C accepted prolonged input overload: 20%
Accuracy	0.1% @25°C ± one digit (inputs: current, voltage, milivoltage, thermoresistance, thermocouple K, J, E); 0.2% @ 25°C (thermocouple N), 0.5% @25°C (thermocouple S, T, R, B)
Stability	50 ppm/°C
Binary outputs	1, 2 or 4 x REL NO 5A/250V AC (resistance), 3A/250V AC (reactance); 0 or 1 x OC (SSR) I _{max} =30mA, U _{max} =30VDC, P _{max} =100mW
Analogue output (available with 2 x REL or OC, see ordering)	<u>active current</u> : operating range 0/4-20 mA (max. 0-24 mA), load resistance 700 Ω max., resolution 13 bit <u>passive current</u> : isolated, operating range 4-20 mA (max. 2,8-24 mA), load resistance 600 Ω @24VDC, resolution 13 bit <u>active voltage</u> : operating range 0/1-5V, 0/2-10V (max. 0-11V), load resistance min. 2000 Ω, resolution 13 bit
Power supply output	24V DC +5%, -10% / max. 100 mA (24V and 85 ÷ 260V AC/DC), stabilized; 24V DC +5% / max. 50 mA (for 12V AC/DC)
Communication interface	RS-485, 8N1 and 8N2, 1200 bit/s ÷ 115200 bit/s, Modbus RTU (not galvanically isolated)
Operating temp.	0°C ÷ +50°C (standard), -20°C ÷ +50°C (option)
Storage temp.	-10°C ÷ +70°C (standard), -20°C ÷ +70°C (depending on option)
Protection class	IP 65 (front), optional integrated frame for panel cut-out sealing; IP 20 (case and connection clips)
Case	panel mounting; material: NORYL - GFN2S E1
Dimensions	<u>case (WxHxD)</u> : 48 x 96 x 100 mm <u>panel cut-out dimensions</u> : 43 x 90,5 mm <u>installation depth</u> : min. 102 mm <u>board thickness</u> : standard 7 mm or other depending on used board thickness brackets (see Accessories)
Weight	230 g max.

DIMENSIONS

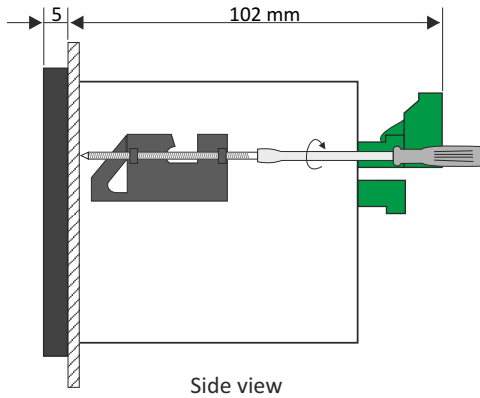

Side view

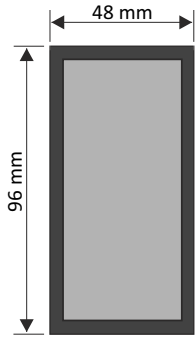

Case dimensions

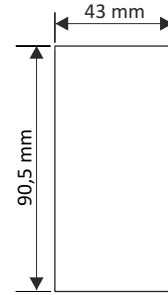

Panel cut-out dimensions

EXAMPLARY PIN ASSIGNMENTS

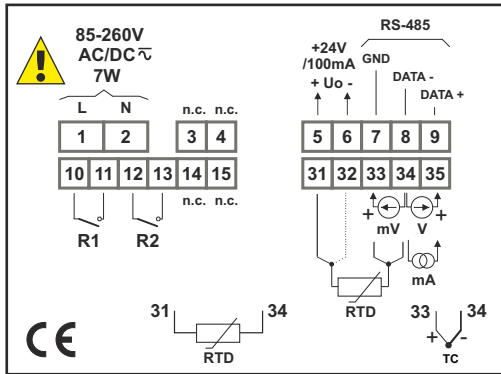

version with 2 x REL

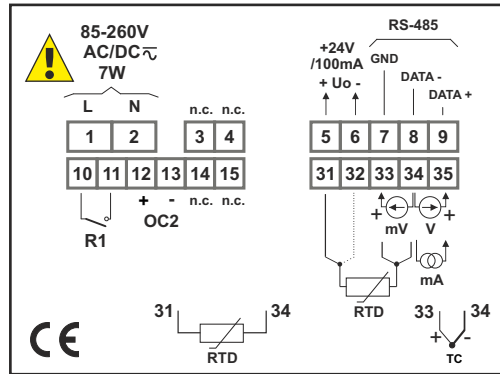

version with 1 x REL and 1 x OC

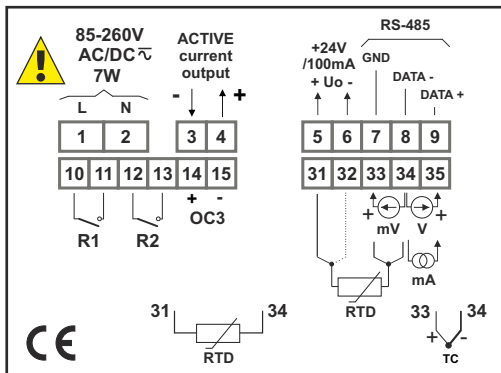

version with 2 x REL, 1 x OC and 1 x AO 0/4-20 mA, active

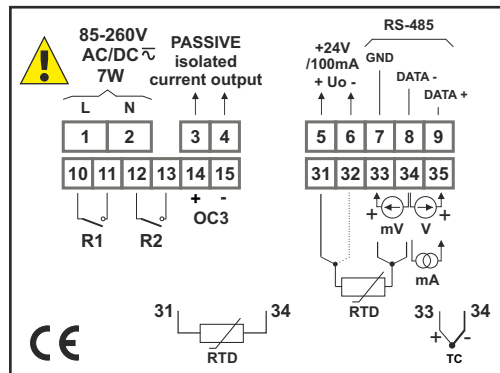

version with 2 x REL, 1 x OC and 1 x AO 4-20 mA, passive

ORDERING

PUR-49D-X-J0-1XXX-10-X-XX1

display colour:
 R : PV - red, SV - green
 G : PV - green, SV - red

type of outputs:
 100 : 2 x REL
 200 : 1 x REL + 1 x OC (SSR)
 111 : 4 x REL
 120 : 2 x REL + 1 x OC (SSR)
 12D : 2 x REL + 1 x OC (SSR) + 1 x AO (0/4-20 mA, active, non-isolated)
 125 : 2 x REL + 1 x OC (SSR) + 1 x AO (4-20 mA, passive, isolated)
 12E : 2 x REL + 1 x OC (SSR) + 1 x AO (0/1-5V, 0/2-10V, active, non-isolated)

options:
 00 : no options
 01 : integrated frame for panel cut-out sealing
 08 : operating temp. -20°C ÷ +50°C
 0P : integrated frame for panel cut-out sealing + operating temp. -20°C ÷ +50°C

power supply:
 3 : 24V AC/DC
 4 : 85V ÷ 260V AC/DC
 5 : 12V AC/DC



MOUNTING PLATES

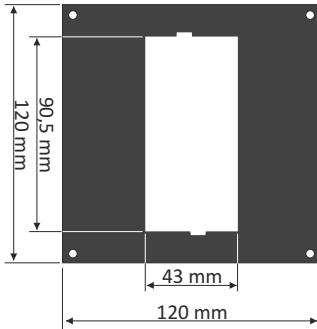

SMP-99/94
to mount 48 x 96 mm
size unit in place
of 96 x 96 mm cut-out

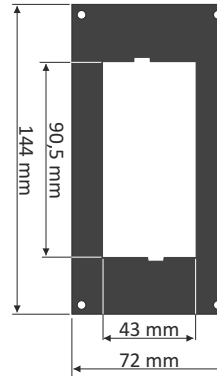

SMP-147/94
to mount 48 x 96 mm
size unit in place
of 144 x 72 mm cut-out

BOARD THICKNESS BRACKETS / ADAPTORS



SPH-07
1 ÷ 7 mm board thickness
brackets (2 pcs)
standard included with device



SPH-45
1 ÷ 45 mm board thickness
brackets (2 pcs)



SPH-05
1 ÷ 5 mm board thickness
brackets (2 pcs)



SRH-94
brackets for mounting devices
on DIN 35/7.5 or 15 rail (2 pcs)

SOFTWARE

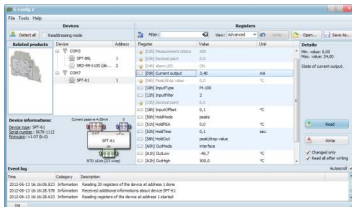

S-Config 2 is used for the simultaneous detection of devices in multiple Modbus RTU networks and allows user to change the configuration of most of them. For each detected device a list of its registers, which the user can modify, is displayed and also additional informations about device parameters (type, address in the network, etc.).

S-Config software can be downloaded from SIMEX website at www.simex.pl

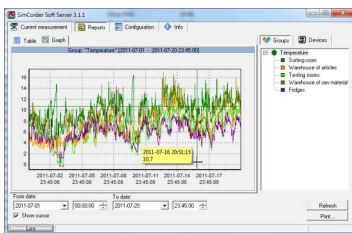

SimCorder Soft is a visualisation application created to facilitate work with advanced networks of the SIMEX devices, for acquisition, visualisation, reporting, archiving, exporting and printing of measurement data from all network devices. You can download measurements from the devices automatically or on demand. There is a possibility of immediate notification about emergency states via SMS or e-mail, which will often allow to quickly resolve an arising problem while avoiding long and expensive stoppages. You can view the measurement data, emergency states and configuration via the internet at every time.

CONVERTERS



The **SRS-U4** module is designed to connect a USB host to slave devices equipped with RS-485 interface. The PC with special software can be used as a host. The **SRS-U4** unit guarantees full galvanic isolation between USB and RS-485 circuits. The converter can work with any devices equipped with RS-485 interface and contains integrated circuit which supports USB 1.1 and USB 2.0 standards. The main purpose is connection of PC host computer with industrial data acquisition and visualisation systems based on RS-485 interface.

The **SRS-U4** can be also manufactured with DIN mounting adaptor.

