

English

Operating manual

Tipping bucket rain gauge
HD2013



Members of GHM GROUP:

GREISINGER

HONSBERG

Martens

Delta OHM

VAL.CO

www.deltaohm.com

Keep for future reference.

TABLE OF CONTENTS

1	INTRODUCTION	3
2	TECHNICAL SPECIFICATIONS	4
3	INSTALLATION	7
3.1	ELECTRICAL CONNECTIONS	7
3.2	CONFIGURATION OF ANALOG OUTPUT	10
3.3	TIPPING BUCKET.....	11
3.4	INSTALLATION MODES	12
4	SERIAL COMMANDS	15
5	SDI-12 PROTOCOL	21
6	MAINTENANCE	28
7	INSTRUMENT STORAGE	29
8	SAFETY INSTRUCTIONS	29
9	ORDERING CODES	30

1 INTRODUCTION

The HD2013 is a reliable and sturdy tipping bucket rain gauge, built entirely from corrosion resistant materials in order to guarantee its durability. So as to ensure accurate measurement even with low temperature climatic conditions or during and after precipitations of snow, a version with heating which is automatically activated around +4 °C has been developed so that snow deposits and ice formations are prevented.

The rain gauge is formed by a metal base on which a tipping bucket is set. The rain collector cone, fixed to the aluminium cylinder, channels the water inside the tipping bucket: once the predefined level is reached, the calibrated bucket rotates under the action of its own weight, discharging the water. During the rotation phase, the normally closed reed contact opens for a fraction of a second, sending an impulse to the counter.

The quantity of rainfall measured is based on the count of the number of times the bucket is emptied: the reed contacts, normally closed, open at the moment of the rotation between one bucket's section and the other. The number of impulses can be detected and recorded by a data logger (e.g. HD2013-DB) or by a pulse counter.

The rain gauge is available with **optional analog output** at choice between 4...20 mA (HD2013...**A**...) or 0...10 Vdc (HD2013...**V**...) or with **optional SDI-12 digital output** (HD2013...**S**...).

The version with 4...20 mA output and the version with SDI-12 output require 7...30 Vdc power supply. The version with 0...10 Vdc output requires 13...30 Vdc power supply. The versions with analog or SDI-12 output are equipped with a backup battery that allows maintaining the rainfall information even after short power supply outages (at least 10 seconds for the versions with analog output, approx. 5 minutes for the version with SDI-12 output).

A removable filter for periodic cleaning and maintenance is inserted in the water collector cone so as to prevent leaves or other elements blocking the end of the hole.

For a better water flow, the collecting cone is treated with a non-adherent product.

In the version with heating HD2013...**R**..., the heating circuit operates with 12 Vdc or 24 Vdc direct voltage (**to be specified when ordering**) and absorbs about 165W. Heating is activated around +4 °C.

When submitting your order, upon request a bird dissuader, made of eight 3 mm diameter spikes, 60 mm in height, can be installed on the rain gauge.

2 TECHNICAL SPECIFICATIONS

Power supply	
basic version	---
with heating	12 or 24 Vdc \pm 10% depending on model
with analog output	7...30 Vdc (4...20 mA version) / 13...30 Vdc (0...10 V version)
with SDI-12 output	7...30 Vdc
Consumption	
basic version	---
with heating	165 W
with analog output	26 mA max. @ 18 Vdc (4...20 mA version) / \approx 4 mA @ 18 Vdc (0...10 V version)
with SDI-12 output	\approx 100 μ A @ 18 Vdc
Contact output	NC contact (opens during tipping). With analog or SDI-12 output options, the contact output is alternative to the analog or SDI-12 output and the rain gauge is factory-configured with analog or SDI-12 output.
Analog output	4...20 mA (only HD2013... A ...) or 0...10 V (only HD2013... V ...)
Digital output	SDI-12 (only HD2013... S ...)
Resolution	0.1 – 0.2 or 0.5 mm/tip depending on model
Accuracy	Version with 0.2 mm @ 50 mm/h nominal resolution: < 1% up to 30 mm/h < 2% up to 40 mm/h < 3% up to 60 mm/h < 4% up to 100 mm/h Version with 0.5 mm @ 50 mm/h nominal resolution: + 2...-3,5% in the interval 0...200 mm/h The error refers to the calculation of the amount of rain using the resolution stated in the rain gauge label. If the amount of rain is calculated using the correction curves as a function of the rainfall rate (fig. 2.1, 2.2 and 2.3), the error is typically less than \pm 2% in the interval 0...200 mm/h. If the HD2013-DB data logger is used, the measurement can be automatically corrected according to the graphs in fig. 2.1, 2.2 and 2.3. With the analog and SDI-12 output options, the curve is stored in the rain gauge itself.
Maximum rainfall rate	600 mm/h (versions with 0.1 and 0.2 mm nominal resolution) 1000 mm/h (version with 0.5 mm nominal resolution)
Operating temperature	
without heating	0...+70 °C
with heating	-20...+70 °C (heating intervention temperature +4 °C)
Protection degree	IP 64
Collector area	400 cm ²
Minimum section of the connecting cable wires	0.5 mm ² for the version without heating 2.5 mm ² for the version with heating

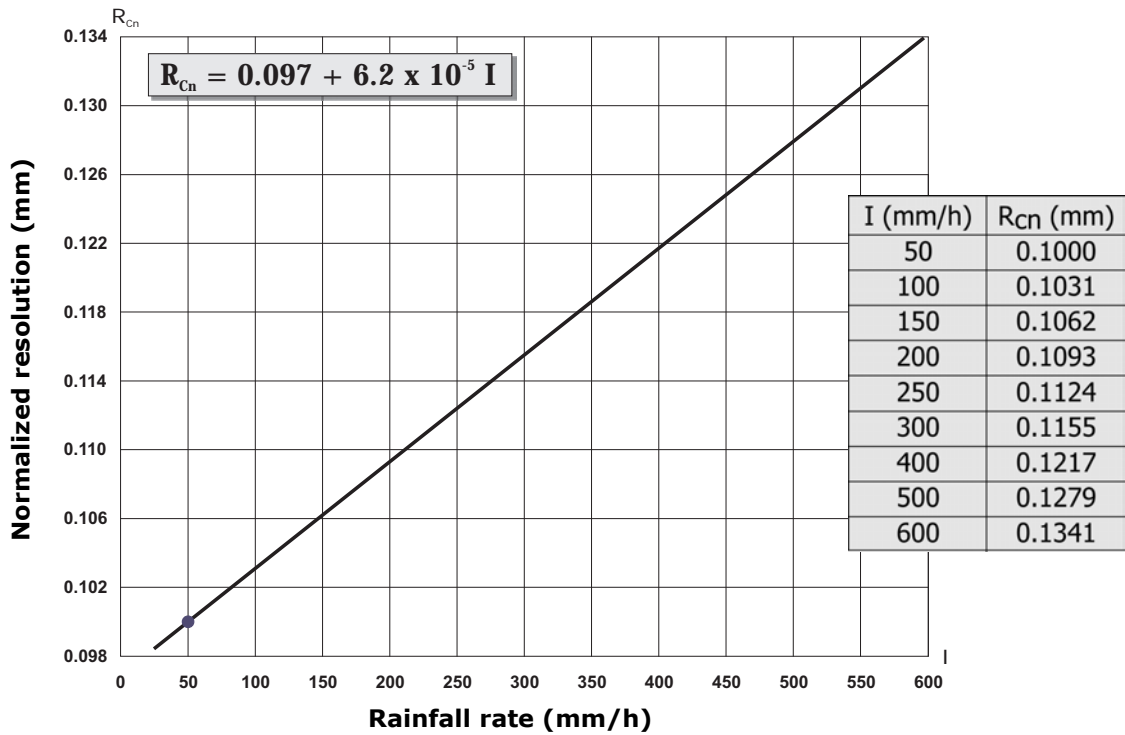

Fig. 2.1 – Normalized resolution (0.1 mm @ 50 mm/h) as a function of the rainfall rate

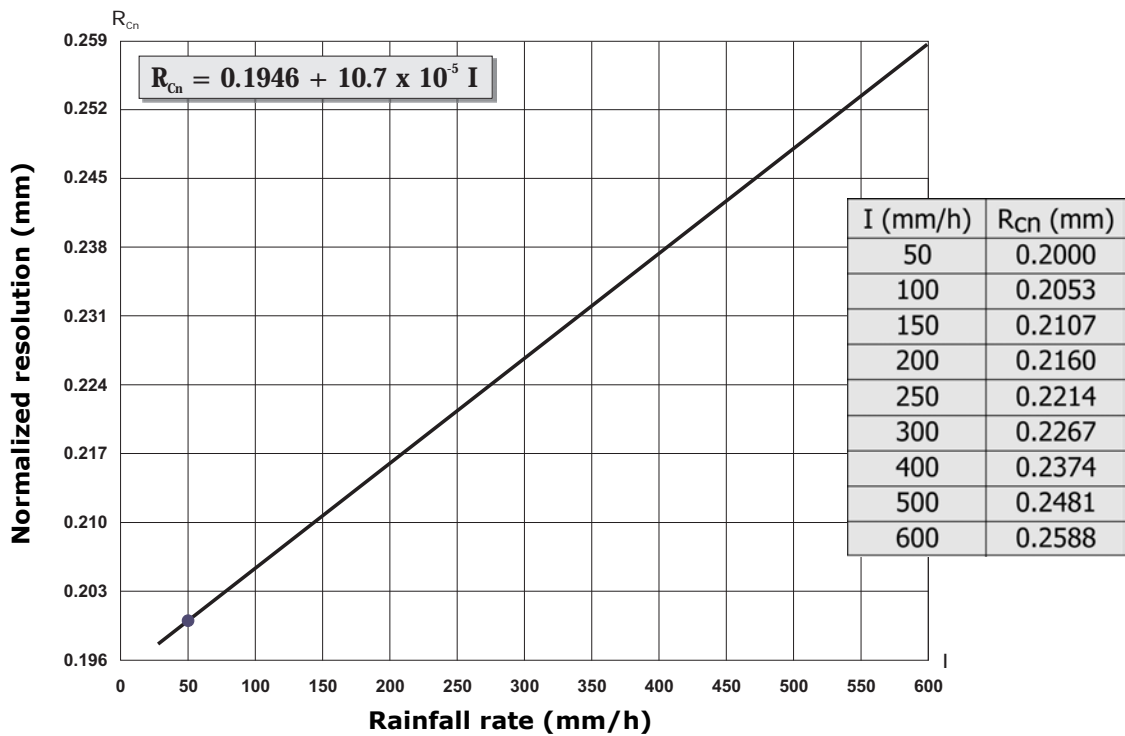

Fig. 2.2 – Normalized resolution (0.2 mm @ 50 mm/h) as a function of the rainfall rate

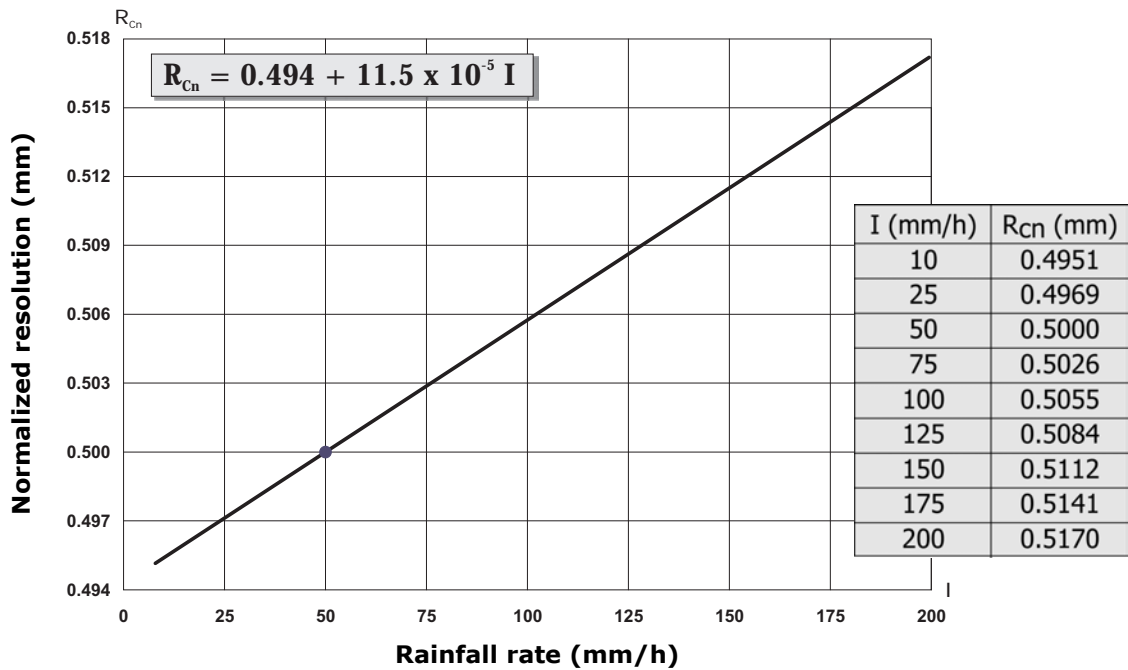

Fig. 2.3 – Normalized resolution (0.5 mm @ 50 mm/h) as a function of the rainfall rate

To correct the measurement depending on the rainfall rate, it is necessary to log, in addition to the number of pulses, also the instants at which the pulses occur.

Example of measurement correction:

Let's assume that a rain gauge with nominal resolution $R_N = 0.204$ mm @ 50 mm/h has generated 25 pulses at the frequency of 1 pulse every 25 seconds.

The rainfall rate can be estimated considering the nominal resolution R_N and the interval between two successive pulses: $I \approx 0.204 \times 3600 / 25 \approx 29.38$ mm/h.

From figure 2.2 we obtain the normalized corrected resolution: $R_{Cn} = 0.198$ mm.

The corrected resolution of the rain gauge is: $R_C = R_{Cn} \times R_N / 0.2 = 0.202$ mm.

The amount of rain detected is $25 \times 0.202 = 5.05$ mm.

3 INSTALLATION

The rain gauge is supplied already calibrated and the calibration value (resolution) is shown on the instrument label.

The instrument must be installed in an open area, away from buildings, trees, etc., ensuring the space over it is free from all objects which could obstruct rain measurements, and in an easily accessible position for the filter to be cleaned periodically.

Avoid installation in areas exposed to gusts of wind, turbulence (for example the top of a hill) as these may distort the measurements.

The rain gauge can be requested in the version for ground installation or for installation raised above the ground.

For ground installation, three adjustable support feet, so that the instrument can be levelled correctly, and holes for fixing to the floor have been provided.

For installation raised above the ground, insert the flange at the base of the instrument in the support mast. At the opposite end, the mast may end with either a flange so that it can be fixed to the floor, or a tip to be driven into the ground. The various fastening systems can be seen in the figures 3.7, 3.8 and 3.9.

For the tipping device to function correctly and so for the measurement to be correct, it is important that the instrument is placed perfectly levelled. The base of the rain gauge is fitted with a bubble level.

For installation, unscrew the three screws at the base of the cylinder that supports the water collector cone.

Attention: a heating resistor is fitted around the cone in the heated version. To disconnect the cone heater, unplug the connector on the upper side of the terminal block protection cover (see fig.3.1).

3.1 ELECTRICAL CONNECTIONS

For the version without heating use a 2-wire cable with 0.5 mm² minimum wires section, for the version with heating use a 4-wire cable with 2.5 mm² minimum wires section.

Use a shielded cable over long distances. Slide the cable through the cable gland and fasten it with the cable fastener located near the entry hole at the base of the rain gauge.

Unscrew the terminal block protection cover and perform the connections as shown in the following figures.

Connection of heating:

The heated version requires power (12 Vdc or 24 Vdc depending on the version supplied) for the resistors: perform the connection as indicated at point 2 of fig. 3.1.

If the connections are set correctly, the LED placed near the terminals will be lit up.

Connection of contact output:

The rain gauge contact output, indicated at point 1 in the figure 3.1, **must be connected to the input of the HD2013-DB rain gauge data logger** (please see the details in the manual of the data logger) **or to a pulse counter or to a data logger**.

To use the contact output in the versions with analog or SDI-12 output option, set the

SW1 switch down, towards the EXTERNAL indication (see the figures 3.2 and 3.3): the analog or SDI-12 output is disabled.

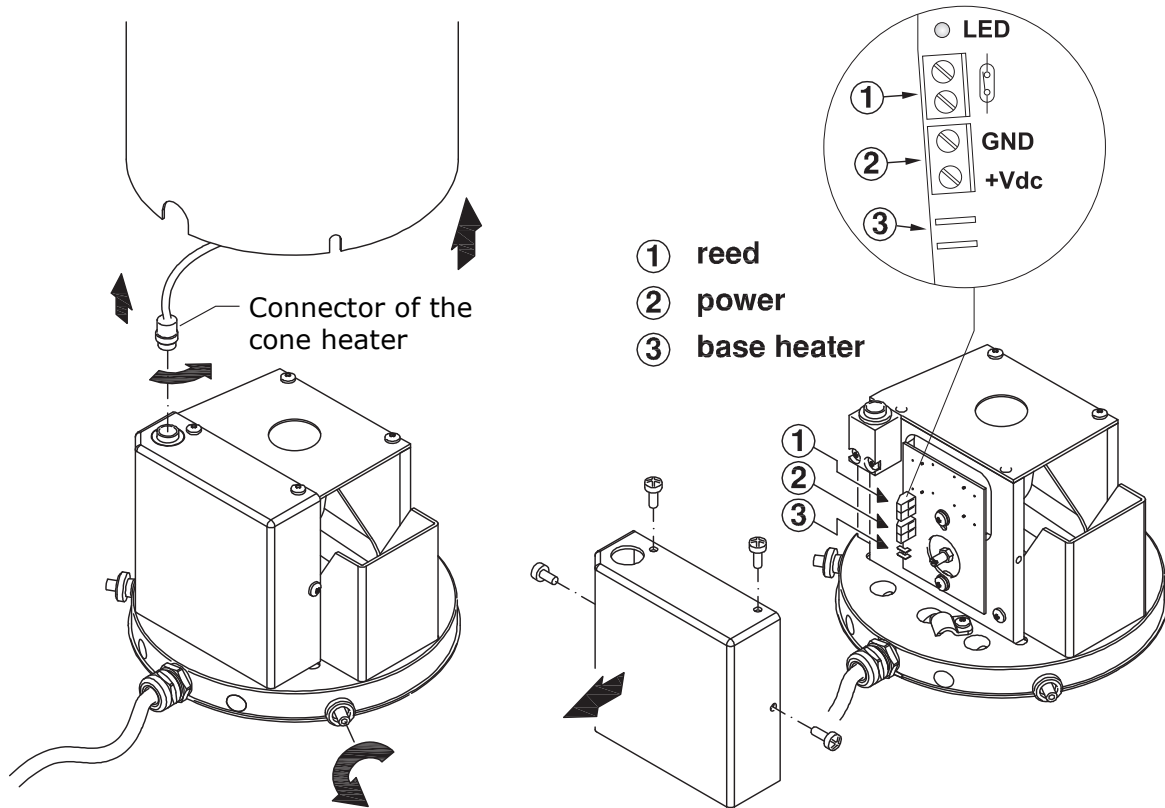

Fig. 3.1 – Connections of contact output and heating

Connection of analog output (only HD2013...A... and HD2013...V...):

Perform the connections as shown in figure 3.2. Set the SW1 switch up, towards the INTERNAL indication (the contact output is disabled).

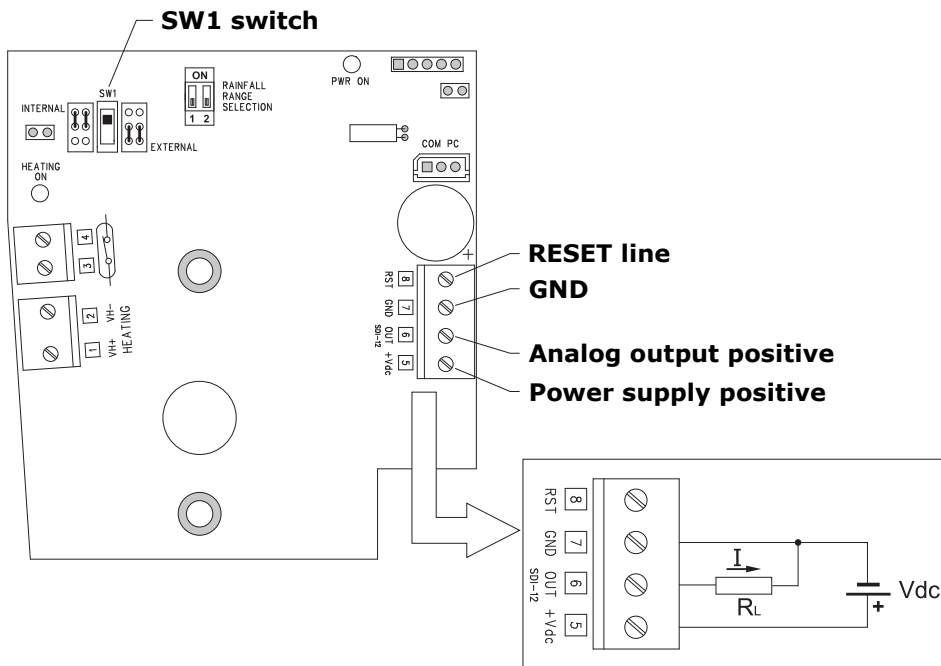

Fig. 3.2 – Connections of analog output

The current analog output is active. The maximum value of the load resistance depends on the power supply value:

$$R_L \text{ max} = 50 \times (V_{dc} - 7) \Omega$$

The minimum value of the load resistance for the version with voltage analog output is 10 KΩ.

In case of a measurement error, the analog output goes to the value 22 mA or 11 V.

The reset line allows the partial amount of rainfall measurement (amount of rainfall from the last reset command) to be remotely reset. During the measurement, the reset line must be connected to GND. To reset, disconnect the line from GND and apply a direct voltage of at least 3 Vdc (and lower than or equal to the power supply) for at least 1 s, then reconnect the line to GND.

Connection of SDI-12 digital output (only HD2013...S...):

Perform the connections as shown in figure 3.3. Set the SW1 switch up, towards the INTERNAL indication (the contact output is disabled).

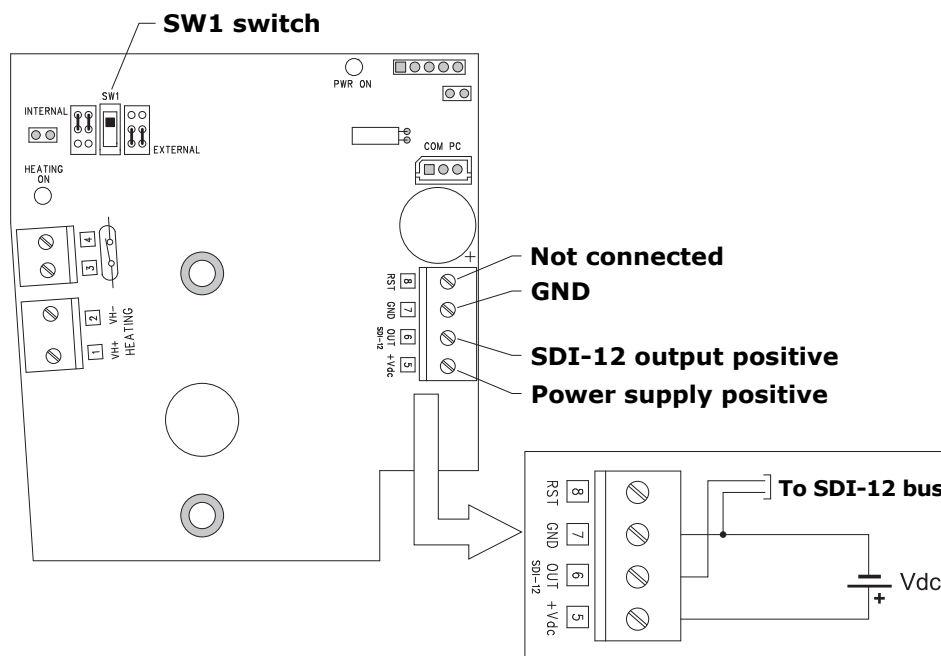
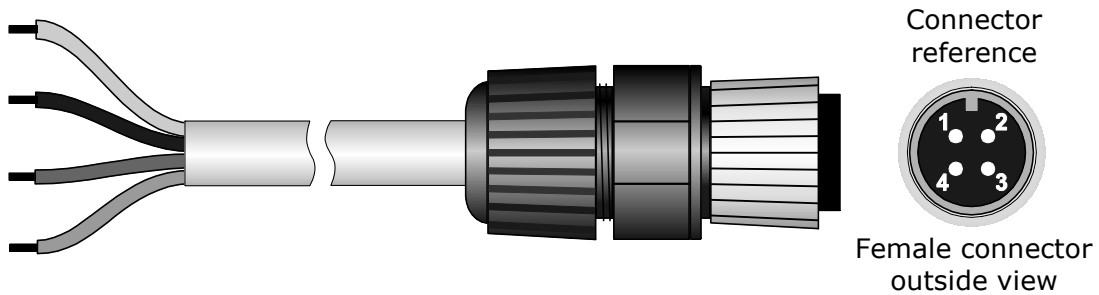

Fig. 3.3 – Connections of SDI-12 digital output

The reset line is not used in the version with digital output: the reset is performed with the appropriate SDI-12 extended command (**aXDRES!**, with **a**=address of the rain gauge).

Connection of the optional CPM12AA4.x cable to the rain gauges with analog or SDI-12 output option:

Connector pin	Function	Wire color
1	Power supply positive (+Vdc)	Red
2	GND	Blue
3	Analog or SDI-12 output positive (OUT)	White
4	Cable shield	Black



The cable shield (black wire) can be left disconnected inside the rain gauge (isolate or cut the wire terminal to avoid unwanted contacts).

3.2 CONFIGURATION OF ANALOG OUTPUT

The analog output is proportional to the partial amount of rainfall (amount of rainfall from the last reset command). The analog output full scale (20 mA or 10 V) can be associated with different values of rainfall. The association can be implemented via hardware, by using the **dip switches** on the circuit board, or via software, by connecting the serial communication port **COM PC** of the rain gauge to the PC.

The dip switches allow setting three rainfall values: 25, 100 or 250 mm (1, 5 or 10 inches if the set unit of measurement is "inches"), as shown in figure 3.4.

If both the dip switches are set to ON, the rainfall value considered is the one set via serial port with the command **CRW** (see the table of the serial commands).

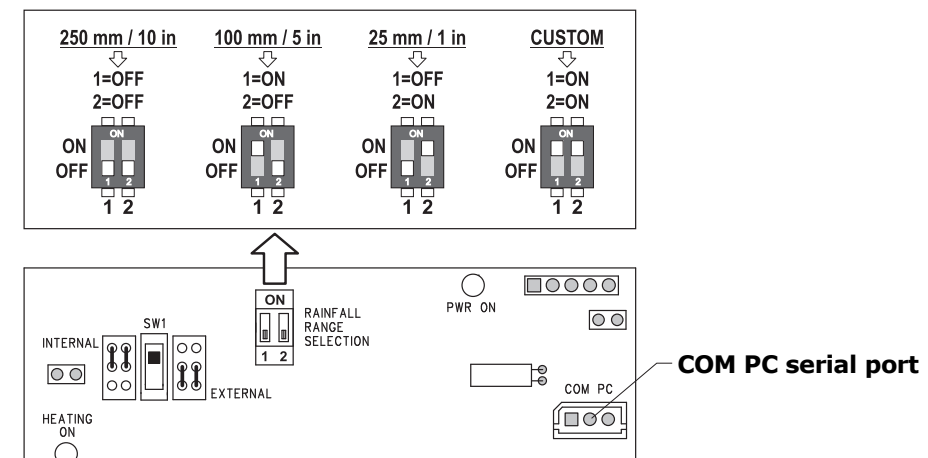

Fig. 3.4 – Dip switches

Warning: after reaching the full scale value, the measurement is reset and the analog output returns to the initial scale value.

3.3 TIPPING BUCKET

The tipping bucket is locked for the transport of the rain gauge. To unlock the bucket, remove the holders as shown in fig.3.5.

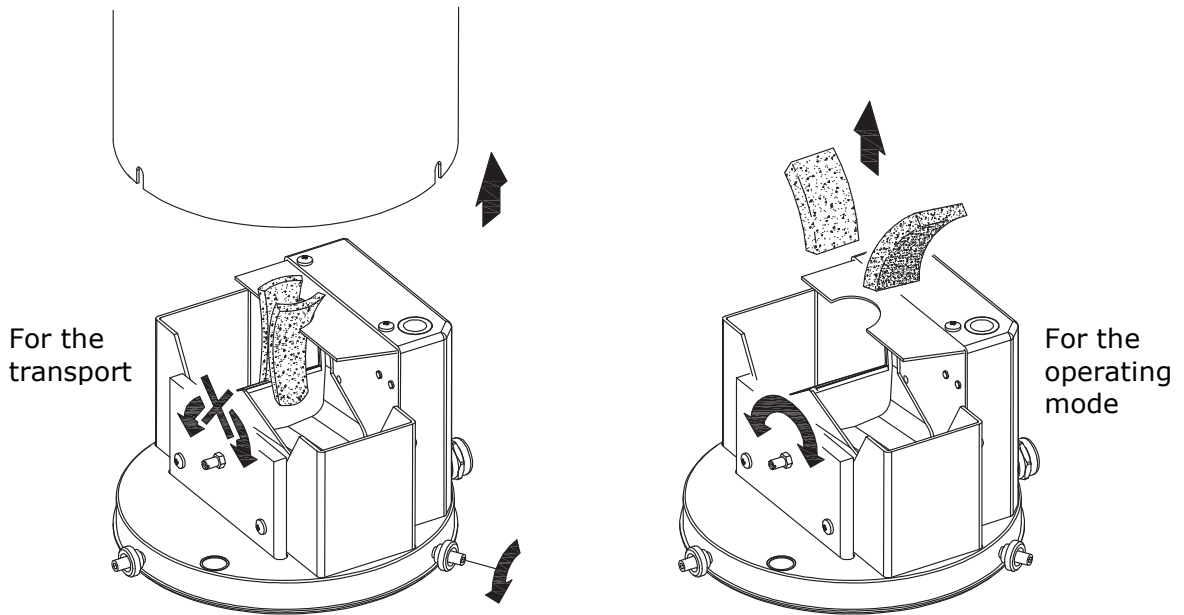

Fig. 3.5 – Locking and unlocking the tipping bucket

The oscillation of the tipping bucket can be adjusted through the two threaded rods located under the bucket, as illustrated in fig. 3.6.

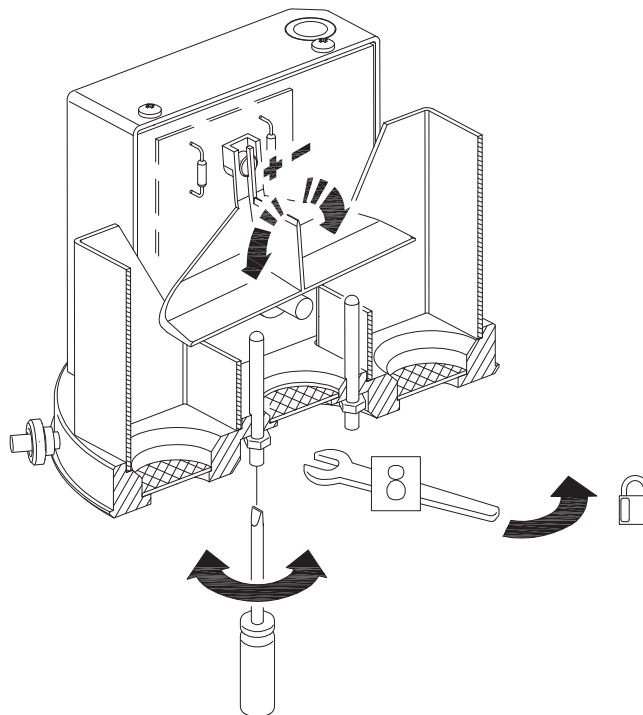

Fig. 3.6 – Adjustment of the tipping bucket

3.4 INSTALLATION MODES

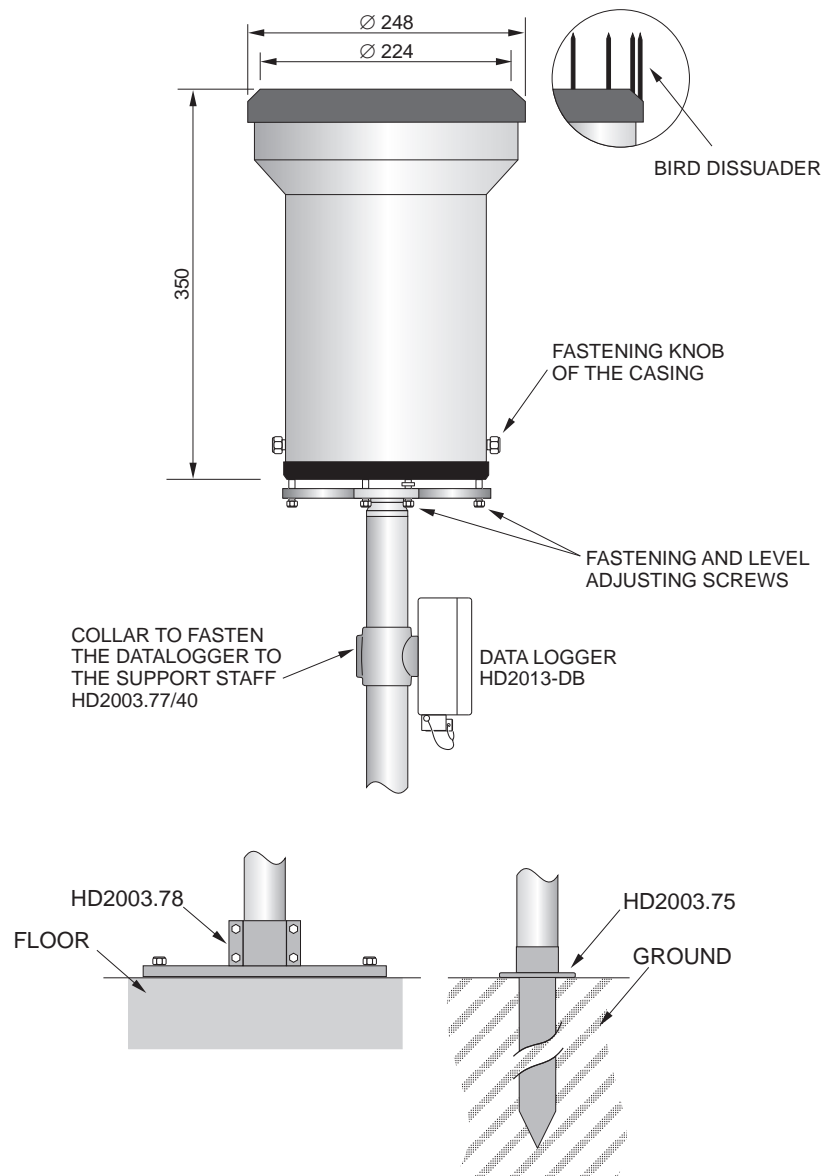

Fig. 3.7 – Mechanical dimensions, installation modes

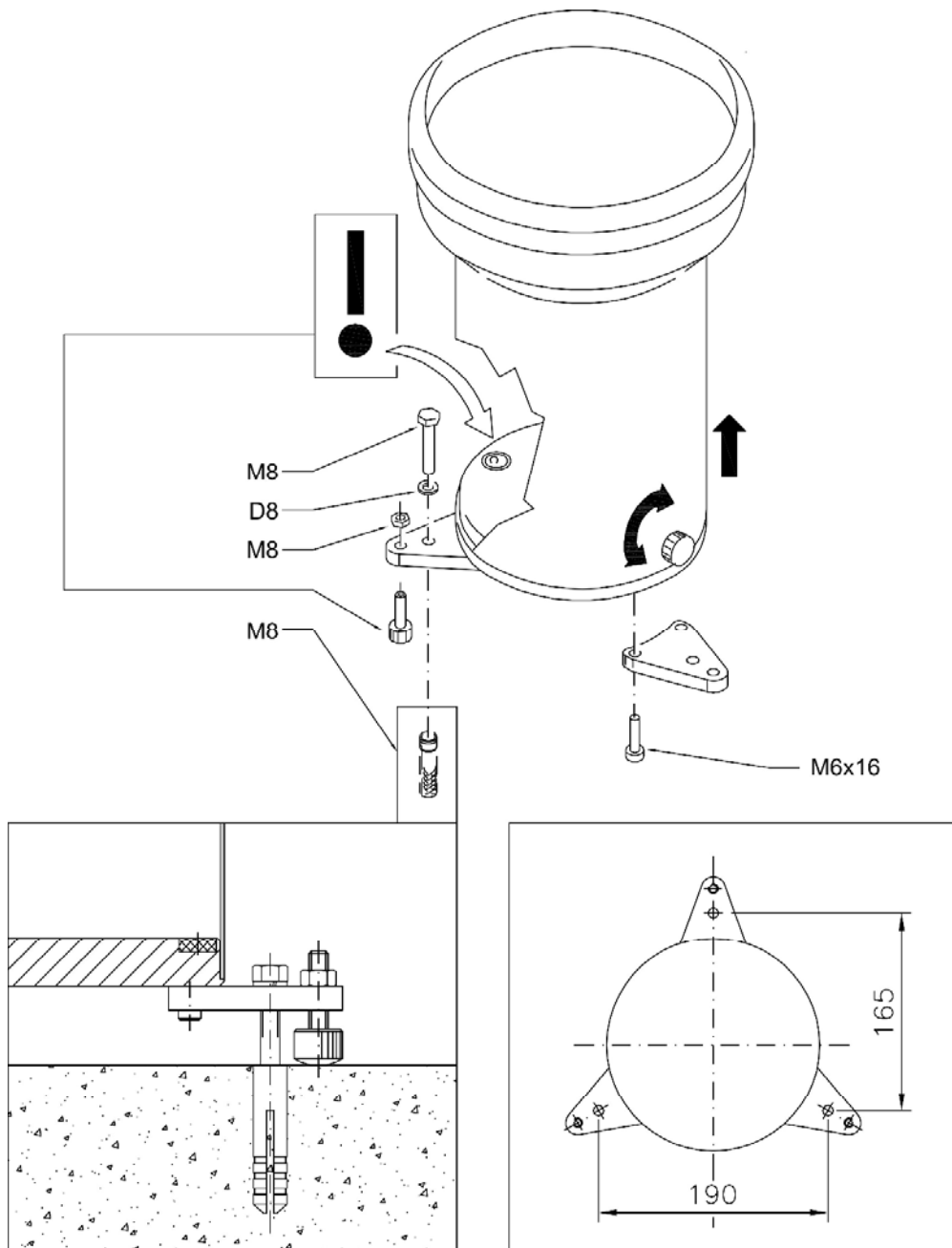

Fig. 3.8 – Ground installation

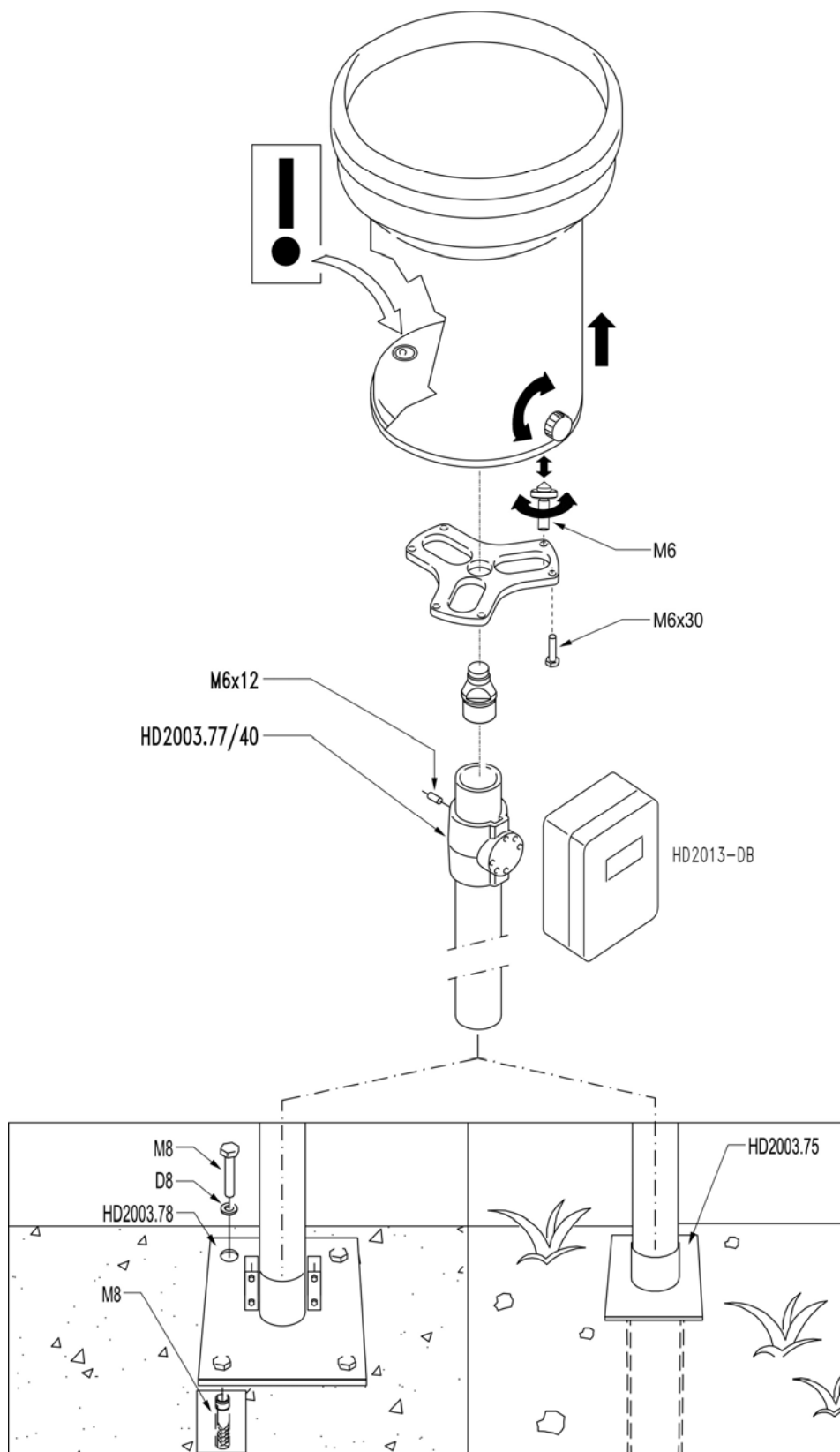

Fig. 3.9 – Installation raised above ground

4 SERIAL COMMANDS

The rain gauges with analog or SDI-12 output option allow editing or checking the operating parameters of the instrument via serial commands.

The editing of the rain gauge parameters requires sending a password via the serial command **PWD**. By default, the password is not set; therefore, it is sufficient to send the command PWD without password to change the parameters. To protect the parameters from unauthorized changes, it is advisable to set a password with the serial command **SUP**. The password remains active for 10 minutes, after which you must resubmit it.

In the serial commands tables below, the column "PWD" indicates whether the execution of the command is password protected.

Rain gauge with analog output:

The configuration is done by connecting the rain gauge **COM PC** serial port to a PC (**RS27** cable for the RS232 connection, **CP27** cable for the USB connection) and sending, through a standard serial communication program, the commands given in the tables below (communication parameters 9600, 8N2).

Note: if the CP27 cable is used, install the corresponding USB drivers in your PC.

Rain gauge with SDI-12 output:

The configuration is done by connecting the rain gauge SDI-12 output and sending extended SDI-12 commands (communication parameters 1200, 7E1) in the following format:

<Address>XD<Command>!

With <Address> = address of the instrument the command is sent to
<Command> = one of the commands given in the tables below

For example, to set °F as temperature unit of measurement in the instrument with address 0, send:

0XDPWDmypass! *Sends the password (assuming password=mypass)*
0XDTUWF! *Sets °F*

The reply to an extended command is always preceded by the address of the instrument that replies.

Serial commands

In the editing commands, the new value of the parameter follows immediately (without spaces interposed) the command identifier.

Password management

Command	Description	PWD
PWDx...x	Sends the password x...x (8 characters max.). Reply of the instrument: USER ACCESS OK if the password is accepted WRONG PASSWORD if the password is not accepted	---
SUPx...x	Sets the string x...x (8 ASCII characters max.) as password. Reply of the instrument: PASS: x...x if the password is accepted INVALID PASSWORD if the password is not accepted	Yes

Date and time

Command	Description	PWD
DSyyyy/mm/dd hh:mm:ss	Sets the date yyyy/mm/dd (year/month/day) and the time hh:mm:ss (hour/minutes/seconds) in the rain gauge. Reply of the instrument: & if date and time are accepted ? if date and time are not correct	Yes
DG	Reads the date (year/month/day) and the time (hour/minutes/seconds) set in the rain gauge. Reply of the instrument: yyyy/mm/dd hh:mm:ss	No

General info

Command	Description	PWD
IR	Reads the manufacturer, the model, the firmware version and the serial number of the rain gauge. Reply of the instrument: v...vm...mf...fs...s, with: v...v (8 characters) = name of the manufacturer (DELTAOHM) m...m (6 characters) = model (HD2013) f...f (3 characters) = firmware version s...s (max. 13 characters) = serial number	No

Unit of measurement

Command	Description	PWD
UWn	Sets the unit of measurement of index <i>n</i> for the amount of rainfall: <i>n</i> =0 ⇒ mm, <i>n</i> =1 ⇒ inches Reply of the instrument: & if the unit of measurement is accepted ? if the index <i>n</i> is not correct	Yes
UR	Reads the unit of measurement of the amount of rainfall set in the rain gauge. Reply of the instrument: 0 if the unit of measurement is "mm" 1 if the unit of measurement is "inches"	No
TUWu	Sets the temperature unit of measurement (*): <i>u</i> =C ⇒ °C, <i>u</i> =F ⇒ °F Reply of the instrument: & if the unit of measurement is accepted ? if the character <i>u</i> is not correct	Yes
TUR	Reads the temperature unit of measurement (*). Reply of the instrument: C if the unit of measurement is "°C" F if the unit of measurement is "°F"	No

(*) The rain gauges with analog or SDI-12 output option are equipped with a temperature sensor which detects the internal temperature of the instrument (**not the air temperature**). The temperature value can be read via the serial commands S1 / S2 or, in the rain gauges with SDI-12 output option, via the appropriate SDI-12 command described in the paragraph "SDI-12 protocol".

Resolution

Command	Description	PWD
BW <i>n</i>	<p>Sets the rain gauge resolution (amount of rainfall corresponding to an emptying of the tipping bucket) of index <i>n</i>:</p> <p><i>n</i>=0 ⇒ 0.1 mm <i>n</i>=1 ⇒ 0.2 mm <i>n</i>=2 ⇒ 0.25 mm <i>n</i>=3 ⇒ 0.5 mm <i>n</i>=4 ⇒ 1.0 mm <i>n</i>=5 ⇒ 0.254 mm (0.01 inches) <i>n</i>=6 ⇒ 0.508 mm (0.02 inches) <i>n</i>=7 ⇒ 1.016 mm (0.04 inches) <i>n</i>=X ⇒ custom value (set via the CCW command)</p> <p>Reply of the instrument: & if the resolution is accepted ? if the index <i>n</i> is not correct</p>	Yes
BR	<p>Reads the rain gauge resolution.</p> <p>The reply of the instrument is the index <i>n</i> of the resolution according to the list given in the description of the editing command BW.</p>	No
CCW <i>n...n</i>	<p>Sets <i>n...n</i> as custom value of the resolution. The value must be between 0.001 and 10.00 and is considered in the unit of measurement (mm or inches) set in the instrument.</p> <p>Example: CCW+0.42 sets 0.42 mm or 0.42 inches, depending on the unit of measurement set, as custom value of the resolution.</p> <p>Reply of the instrument: & if the value <i>n...n</i> is accepted ? if the value <i>n...n</i> is not correct</p> <p><i>Warning</i>: the command CCW sets the value but not the use of the custom resolution; to use the custom resolution, the command BWX should be sent (see the command BW described above).</p>	Yes
CCR	<p>Reads the custom value of the resolution. The value is considered in the unit of measurement (mm or inches) set in the instrument.</p>	No

Output contact type

Command	Description	PWD
TNW <i>n</i>	<p>Sets the rain gauge output contact as normally open or normally closed: <i>n</i>=0 ⇒ Normally OPEN, <i>n</i>=1 ⇒ Normally CLOSED</p> <p>Reply of the instrument: & if the setting is accepted ? if the index <i>n</i> is not correct</p>	Yes
TNR	<p>Reads the type of the rain gauge output contact.</p> <p>Reply of the instrument: 0 if the contact is normally OPEN 1 if the contact is normally CLOSED</p>	No

Analog output (only HD2013...A... and HD2013...V...)

Command	Description	PWD
CPOE	Enables the offset of the analog output initial value: 4...20 mA or 2...10 V. Reply of the instrument: &	Yes
CPOD	Disables the offset of the analog output initial value: 0...20 mA or 0...10 V. Reply of the instrument: &	Yes
CPOR	Reads the enabling state of the offset of the analog output initial value. Reply of the instrument: 0 if the offset is disabled (0...20 mA or 0...10 V) 1 if the offset is enabled (4...20 mA or 2...10 V)	No
CRW <i>n...n</i>	Sets <i>n...n</i> as the amount of rainfall corresponding to the analog output full scale. The value must be between 0.01 and 9999.00 and is considered in the unit of measurement (mm or inches) set in the instrument. Example: CRW+80.00 sets 80 mm or 80 inches, depending on the unit of measurement set, as value corresponding to 20 mA or 10 V. Reply of the instrument: & if the value <i>n...n</i> is accepted ? if the value <i>n...n</i> is not correct	Yes
CRR	Reads the amount of rainfall corresponding to the analog output full scale. The value is considered in the unit of measurement (mm or inches) set in the instrument.	No

Printing of the measurements

Command	Description	PWD
S0	Stops the continuous printing of the measurements. Reply of the instrument: &	No
S1	Single printing of the measurement values, considered in the unit of measurement set in the instrument. Reply of the instrument: $M_1 M_2 M_3 M_4 M_5$, with: M_1 = total amount of rainfall (from when the instrument is powered) M_2 = partial amount of rainfall (from the last reset operation) M_3 = amount of rainfall in the current day M_4 = amount of rainfall in the previous day M_5 = internal temperature Example: the reply +873.4+15.8+2.6+3.4+15.3 indicates that the internal temperature is 15.3 °C and the amount of rainfall is: 873,4 mm or inches from when the instrument is powered 15,8 mm or inches from the last reset operation 2,6 mm or inches today 3,4 mm or inches yesterday <i>Note:</i> after reaching 99999.99, the total rainfall counter restarts from zero.	No
S2	Continuous printing (once per second) of the measurement values, considered in the unit if measurement set in the instrument. The reply of the instrument is in the same form described for the command S1.	No

Reset

Command	Description	PWD
RES	Resets the partial rainfall counter. Reply of the instrument: &	Yes
REA	Resets all the rainfall counters. Reply of the instrument: &	Yes
HRS	Resets the electronic board (with consequent reset of all the measuring counters).	Yes

Correction of the measurement

To increase the measurement accuracy, a measurement correction table as a function of the rainfall rate is stored in the rain gauge at the factory.

The correction is useful because during the emptying time of the tipping bucket, rain is not collected from the bucket and the amount of rain in the absence of correction is therefore underestimated. The correction to be made is greater the higher is the rainfall rate (greater number of cycles in the time unit).

The correction table can be modified by the user. The rain gauge allows you to set ten multiplication factors (numbered from 0 to 9) of the nominal resolution, each corresponding to a range of rainfall rate.

Command	Description	PWD
TE	Enables the measurement correction as a function of the rainfall rate. Reply of the instrument: &	Yes
TD	Disables the measurement correction as a function of the rainfall rate. Reply of the instrument: &	Yes
TR	Reads the enabling state of the measurement correction as a function of the rainfall rate. Reply of the instrument: 0 if the correction is disabled 1 if the correction is enabled	No
CTS	Starts the correction table writing procedure. Reply of the instrument: CALIBRATION_STARTED	Yes
CTE	Ends the correction table writing procedure and saves the entered values. Reply of the instrument: CALIBRATION_ENDED	Yes
CTWi+r...r+k...k	Set the multiplication factor of index i to the value $k...k$. The multiplication factor is applied if the rainfall rate is between $r...r$ (considered in mm/h or in/h depending on the unit of measurement set in the instrument) and the rate value defined for the multiplication factor of index $i+1$ (see the example below). The multiplication factor must be between 0.500 and 2.000. The rainfall rate must be between 0 and 7200. Reply of the instrument: & if the parameters are correct ? if the parameters are not correct	Yes

Command	Description	PWD
CTR <i>i</i>	<p>Reads the setting of the multiplication factor of index <i>i</i>.</p> <p>Reply of the instrument: <i>r...rk...k</i>, with: <i>r...r</i> = rainfall rate corresponding to the multiplication factor <i>k...k</i> = value of the multiplication factor</p> <p>Example: +50+1 indicates that the multiplication factor is 1 and the corresponding rainfall rate is 50 (mm/h or in/h).</p>	No

When you set the correction table, it is mandatory to enter in ascending order all the ten multiplication factors. The rate corresponding to the multiplication factor of index *i* must be greater or equal to the rate corresponding to the multiplication factor of index *i*-1.

Example

To change the default table and implement the following correction table:

		Rainfall rate (mm/h)									
		0...25	25...75	75...100	100...150	150...200	200...250	250...300	300...350	350...400	400...
K		0.98	1	1.02	1.04	1.06	1.09	1.10	1.14	1.18	1.22

send, exactly in the order shown, the following commands:

```

CTS
CTW0+0+0.98
CTW1+25+1
CTW2+75+1.02
CTW3+100+1.04
CTW4+150+1.06
CTW5+200+1.09
CTW6+250+1.10
CTW7+300+1.14
CTW8+350+1.18
CTW9+400+1.22
CTE

```

Note that the sequence of the CTW commands must be preceded by the command CTS and followed by the command CTE.

5 SDI-12 PROTOCOL

The **HD2013...S...** rain gauge is equipped with an SDI-12 communication interface compliant with the version 1.3 of the protocol, which allows the connection to SDI-12 sensor networks.

The communication parameters of the protocol are:

- Baud Rate = 1200
- Data bits = 7
- Parity = Even (E)
- Stop bits = 1

Communication with the instrument is performed by sending a command in the following format:

<Address><Command>!

With <Address> = address of the instrument the command is sent to
 <Command> = type of operation requested to the instrument

The instrument reply is as follows:

<Address><Data><CR><LF>

With <Address> = address of the replying instrument
 <Data> = information sent by the instrument
 <CR> = ASCII character *Carriage Return*
 <LF> = ASCII character *Line Feed*

The table below shows the available SDI-12 commands. For consistency with the documentation of the SDI-12 standard, the instrument address is indicated in the table with the letter **a**. The rain gauge leaves the factory with address preset to 0. The address can be changed by using the proper SDI-12 command reported in the table.

SDI-12 Commands

Command	Instrument reply	Description
a!	a<CR><LF>	Verifies the presence of the instrument.
aI!	allccccccmmmmmmvvvsssssss<CR><LF> with: a = address of the instrument (1 character) ll = SDI-12 compliant version (2 characters) ccccccc = manufacturer (8 characters) mmmmmm = instrument model (6 characters) vvv = firmware version (3 characters) sssssss = serial number (8 characters) => Example of response: 013DeltaOhmTIPSDI10013201518 with: 0 = instrument address 13 = SDI-12 version 1.3 compliant DeltaOhm = manufacturer's name TIPSDI = instrument model (<i>SDI-12 rain gauge</i>) 100 = firmware version 1.0.0 13201518 = serial number	Requests for information from the instrument.

Command	Instrument reply	Description
aAb! Where: b =new address	b<CR><LF> Note: if the b character is not an acceptable address, the instrument responds with a instead of b.	Modification of the instrument address.
?!	a<CR><LF>	Request of the address of the instrument. If more than one sensor is connected to the bus, a conflict occurs.
TYPE M COMMANDS (START MEASUREMENT)		
Total amount of rainfall		
aM!	atttn<CR><LF> with: ttt = number of seconds necessary for the instrument to make the measure available (3 characters) n = number of detected variables (1 character) Note: ttt = 000 means that datum is immediately available.	Request of detection of the total amount of rainfall.
aD0!	a+n+r...r<CR><LF> with: n = number of emptying of the tipping bucket r...r = total amount of rainfall in the unit of measurement set in the instrument (mm or inches) ⇒ Example of response: 0+48+9.6 The instrument with address 0 has recorded 48 emptying of the tipping bucket and the total amount of rainfall is 9.6 mm or inches depending on the set unit. <i>Note:</i> after reaching 99999.99, the total rainfall counter restarts from zero.	Reads the total amount of rainfall.
Partial amount of rainfall		
aM1!	atttn<CR><LF> with: ttt = number of seconds necessary for the instrument to make the measure available (3 characters) n = number of detected variables (1 character) Note: ttt = 000 means that datum is immediately available.	Request of detection of the partial amount of rainfall.
aD0!	a+n+r...r<CR><LF> with: n = number of emptying of the tipping bucket r...r = partial amount of rainfall in the unit of measurement set in the instrument (mm or inches) ⇒ Example of response: 0+12+2.4 The instrument with address 0 has recorded 12 emptying of the tipping bucket and the partial amount of rainfall is 2.4 mm or inches depending on the set unit. <i>Note:</i> after reaching 99999.99, the partial rainfall counter restarts from zero.	Reads the partial amount of rainfall.

Command	Instrument reply	Description
Amount of rainfall in the current day		
aM2!	atttn<CR><LF> with: ttt = number of seconds necessary for the instrument to make the measure available (3 characters) n = number of detected variables (1 character) Note: ttt = 000 means that data are immediately available.	Request of detection of the amount of rainfall in the current day.
aD0!	a+n+r...r<CR><LF> with: n = number of emptying of the tipping bucket r...r = amount of rainfall in the current day in the unit of measurement set in the instrument (mm or inches) ⇒ Example of response: 0+2+0.4 The instrument with address 0 has recorded 2 emptying of the tipping bucket and the amount of rainfall today is 0.4 mm or inches depending on the set unit.	Reads the amount of rainfall in the current day.
Amount of rainfall in the previous day		
aM3!	atttn<CR><LF> with: ttt = number of seconds necessary for the instrument to make the measure available (3 characters) n = number of detected variables (1 character) Note: ttt = 000 means that data are immediately available.	Request of detection of the amount of rainfall in the previous day.
aD0!	a+n+r...r<CR><LF> with: n = number of emptying of the tipping bucket r...r = amount of rainfall in the previous day in the unit of measurement set in the instrument (mm or inches) ⇒ Example of response: 0+8+1.6 The instrument with address 0 has recorded 2 emptying of the tipping bucket and the amount of rainfall yesterday was 1.6 mm or inches depending on the set unit.	Reads the amount of rainfall in the previous day.

Command	Instrument reply	Description
Rainfall rate		
aM4!	attn<CR><LF> with: ttt = number of seconds necessary for the instrument to make the measure available (3 characters) n = number of detected variables (1 character) Note: ttt = 000 means that data are immediately available.	Request of detection of the current rainfall rate.
aD0!	a+r...r<CR><LF> with: r...r = rainfall rate in the unit of measurement set in the instrument (mm/h or in/h) ⇒ Example of response: 0+7.3 The instrument with address 0 measures a rate of 7.3 mm/h or in/h depending on the set unit.	Reads the current rainfall rate.
Power supply voltage and internal temperature		
aM5!	attn<CR><LF> with: ttt = number of seconds necessary for the instrument to make the measures available (3 characters) n = number of detected variables (1 character) Note: ttt = 000 means that data are immediately available.	Request of detecting the power supply voltage and the internal temperature of the rain gauge.
aD0!	a+v...v+t...t <CR><LF> with: v...v = power supply voltage in V t...t = internal temperature in the unit of measurement set in the instrument (°C or °F) ⇒ Example of response: 0+12.0+15.3 The instrument with address 0 has 12.0 power supply voltage and 15.3 °C internal temperature (if °C is the set unit).	Reads the power supply voltage and the internal temperature of the rain gauge.
Partial amount of rainfall with automatic counter reset		
aM6!	attn<CR><LF> with: ttt = number of seconds necessary for the instrument to make the measure available (3 characters) n = number of detected variables (1 character) Note: ttt = 000 means that datum is immediately available.	Request of detection of the partial amount of rainfall and subsequent reset of the corresponding counter.
aD0!	a+n+r...r<CR><LF> with: n = number of emptying of the tipping bucket r...r = partial amount of rainfall in the unit of measurement set in the instrument (mm or inches)	Reads the partial amount of rainfall and resets the corresponding counter. <i>Note:</i> as aM1! Command, but after reading, the partial rainfall counter is reset.

Command	Instrument reply	Description
TYPE C COMMANDS (START CONCURRENT MEASUREMENT)		
Total amount of rainfall		
aC!	attn<CR><LF> with: ttt = number of seconds necessary for the instrument to make the measure available (3 characters) n = number of detected variables (1 character) Note: ttt = 000 means that datum is immediately available.	Request of detection of the total amount of rainfall.
aD0!	a+n+r...r<CR><LF> with: n = number of emptying of the tipping bucket r...r = total amount of rainfall in the unit of measurement set in the instrument (mm or inches)	Reads the total amount of rainfall.
Partial amount of rainfall		
aC1!	attn<CR><LF> with: ttt = number of seconds necessary for the instrument to make the measure available (3 characters) n = number of detected variables (1 character) Note: ttt = 000 means that datum is immediately available.	Request of detection of the partial amount of rainfall.
aD0!	a+n+r...r<CR><LF> with: n = number of emptying of the tipping bucket r...r = partial amount of rainfall in the unit of measurement set in the instrument (mm or inches)	Reads the partial amount of rainfall.
Amount of rainfall in the current day		
aC2!	attn<CR><LF> with: ttt = number of seconds necessary for the instrument to make the measure available (3 characters) n = number of detected variables (1 character) Note: ttt = 000 means that data are immediately available.	Request of detection of the amount of rainfall in the current day.
aD0!	a+n+r...r<CR><LF> with: n = number of emptying of the tipping bucket r...r = amount of rainfall in the current day in the unit of measurement set in the instrument (mm or inches)	Reads the amount of rainfall in the current day.

Command	Instrument reply	Description
Amount of rainfall in the previous day		
aC3!	attn<CR><LF> with: ttt = number of seconds necessary for the instrument to make the measure available (3 characters) n = number of detected variables (1 character) Note: ttt = 000 means that data are immediately available.	Request of detection of the amount of rainfall in the previous day.
aD0!	a+n+r...r<CR><LF> with: n = number of emptying of the tipping bucket r...r = amount of rainfall in the previous day in the unit of measurement set in the instrument (mm or inches)	Reads the amount of rainfall in the previous day.
Rainfall rate		
aC4!	attn<CR><LF> with: ttt = number of seconds necessary for the instrument to make the measure available (3 characters) n = number of detected variables (1 character) Note: ttt = 000 means that data are immediately available.	Request of detection of the current rainfall rate.
aD0!	a+r...r<CR><LF> with: r...r = rainfall rate in the unit of measurement set in the instrument (mm/h or in/h)	Reads the current rainfall rate.
Power supply voltage and internal temperature		
aC5!	attn<CR><LF> with: ttt = number of seconds necessary for the instrument to make the measures available (3 characters) n = number of detected variables (1 character) Note: ttt = 000 means that data are immediately available.	Request of detecting the power supply voltage and the internal temperature of the rain gauge.
aD0!	a+v...v+t...t <CR><LF> with: v...v = power supply voltage in V t...t = internal temperature in the unit of measurement set in the instrument (°C or °F)	Reads the power supply voltage and the internal temperature of the rain gauge.

Command	Instrument reply	Description
Partial amount of rainfall with automatic counter reset		
aC6!	attn<CR><LF> with: ttt = number of seconds necessary for the instrument to make the measure available (3 characters) n = number of detected variables (1 character) Note: ttt = 000 means that datum is immediately available.	Request of detection of the partial amount of rainfall and subsequent reset of the corresponding counter.
aD0!	a+n+r...r<CR><LF> with: n = number of emptying of the tipping bucket r...r = partial amount of rainfall in the unit of measurement set in the instrument (mm or inches)	Reads the partial amount of rainfall and resets the corresponding counter.
TYPE R COMMAND (CONTINUOUS MEASUREMENTS)		
aR0!	a+n+r...r<CR><LF> with: n = number of emptying of the tipping bucket r...r = total amount of rainfall in the unit of measurement set in the instrument (mm or inches)	Reads the total amount of rainfall.
aR1!	a+n+r...r<CR><LF> with: n = number of emptying of the tipping bucket r...r = partial amount of rainfall in the unit of measurement set in the instrument (mm or inches)	Reads the partial amount of rainfall.
aR2!	a+n+r...r<CR><LF> with: n = number of emptying of the tipping bucket r...r = amount of rainfall in the current day in the unit of measurement set in the instrument (mm or inches)	Reads the amount of rainfall in the current day.
aR3!	a+n+r...r<CR><LF> with: n = number of emptying of the tipping bucket r...r = amount of rainfall in the previous day in the unit of measurement set in the instrument (mm or inches)	Reads the amount of rainfall in the previous day.
aR4!	a+r...r<CR><LF> with: r...r = rainfall rate in the unit of measurement set in the instrument (mm/h or in/h)	Reads the current rainfall rate.
aR5!	a+v...v+t...t <CR><LF> with: v...v = power supply voltage in V t...t = internal temperature in the unit of measurement set in the instrument (°C or °F)	Reads the power supply voltage and the internal temperature of the rain gauge.

Command	Instrument reply	Description
aR6!	a+n+r...r<CR><LF> with: n = number of emptying of the tipping bucket r...r = partial amount of rainfall in the unit of measurement set in the instrument (mm or inches)	Reads the partial amount of rainfall and resets the corresponding counter.

In addition to the above-mentioned commands, the rain gauge also implements the corresponding commands with CRC, that require to add a 3-character CRC code at the end of the reply before <CR><LF>. The format of these commands is obtained from the previous by adding the letter C: aMC!, aMC1!, aMC2!, aMC3!, aMC4, aMC5!, aMC6!, aCC!, aCC1!, aCC2!, aCC3!, aCC4!, aCC5!, aCC6!, aRC0!, aRC1!, aRC2!, aRC3!, aRC4!, aRC5!, aRC6!.

6 MAINTENANCE

Verify filters cleanliness periodically; check that there is no debris, leaves, dirt or anything else that might obstruct the flowing of water. Check that the tipping bucket contains no deposits of dirt, sand or any other obstruction. If necessary, the surfaces can be cleaned with non-aggressive detergent.

7 INSTRUMENT STORAGE

Instrument storage conditions:

- Temperature: -30...+70 °C.
- Humidity: less than 90 %RH no condensation.
- In storage, avoid places where:
 - humidity is high;
 - the instrument is exposed to direct sun radiation;
 - the instrument is exposed to a high temperature source;
 - high vibration levels are present;
 - the instrument may be exposed to vapor, salt and/or corrosive gas.

8 SAFETY INSTRUCTIONS

General safety instructions

The instrument has been manufactured and tested in accordance with the safety standard EN61010-1:2010 "Safety requirements for electrical equipment for measurement, control and laboratory use" and has left the factory in perfect safety technical conditions.

The instrument proper operation and operating safety can be ensured only if all standard safety measures as well as the specific measures described in this manual are followed.

The instrument proper operation and operating safety can be ensured only in the climatic conditions specified in this manual.

Do not use the instruments in places where there are:

- Corrosive or flammable gases.
- Direct vibrations or shocks to the instrument.
- High-intensity electromagnetic fields, static electricity.

Do not remove the cylindrical cover of the instrument before unplugging the power cable of the heater.

Ensure that there is the system ground (Protective Earth) and the connecting cable is in good condition.

User obligations

The instrument operator shall follow the directives and regulations below that refer to the treatment of dangerous materials:

- EEC directives on workplace safety.
- National law regulations on workplace safety.
- Accident prevention regulations.

9 ORDERING CODES

HD2013

			<p>Mast / bird spikes kit: Blank = ground installation with feet, without bird spikes H0 = installation on Ø40 mm mast (not supplied), without bird spikes H1 = installation on Ø40 mm mast, with 1 m mast, without bird spikes H5 = installation on Ø40 mm mast, with 500 mm mast, without bird spikes K = ground installation with feet, with bird spikes K0 = installation on Ø40 mm mast (not supplied), with bird spikes K1 = installation on Ø40 mm mast, with 1 m mast, with bird spikes K5 = installation on Ø40 mm mast, with 500 mm mast, with bird spikes</p>
			<p>Heating: Blank = not heated R = heated – power voltage 24 Vdc R1 = heated – power voltage 12 Vdc</p>
			<p>Output: Blank = contact A = contact + analog 4...20 mA V = contact + analog 0...10 V S = contact + digital SDI-12</p>
			<p>Resolution: Blank = 0,2 mm /1 = 0.1 mm /5 = 0.5 mm</p>

The mast base (with tip or flat) must be ordered separately.

Accessories:

- HD2003.75** Base with tip for the ground to support the rain gauge raised above ground.
- HD2003.78** Flat base for fastening the support of the rain gauge raised above ground.

DELTA OHM metrology laboratories LAT N° 124 are ISO/IEC 17025 accredited by ACCREDIA for Temperature, Humidity, Pressure, Photometry / Radiometry, Acoustics and Air Velocity. They can supply calibration certificates for the accredited quantities.



DICHIARAZIONE DI CONFORMITÀ UE
EU DECLARATION OF CONFORMITY

Delta Ohm S.r.L. a socio unico – Via Marconi 5 – 35030 Caselle di Selvazzano – Padova – ITALY

Documento Nr. / Mese.Anno: **5072 / 11.2019**
Document-No. / Month.Year :

Si dichiara con la presente, in qualità di produttore e sotto la propria responsabilità esclusiva, che i seguenti prodotti sono conformi ai requisiti di protezione definiti nelle direttive del Consiglio Europeo:
We declare as manufacturer herewith under our sole responsibility that the following products are in compliance with the protection requirements defined in the European Council directives:

Codice prodotto:
Product identifier : **HD2013...**

Descrizione prodotto:
Product description : **Pluviometro a vaschetta basculante**
Tipping bucket rain gauge

I prodotti sono conformi alle seguenti Direttive Europee:
The products conform to following European Directives:

Direttive / Directives	
2014/30/EU	Direttiva EMC / EMC Directive
2014/35/EU	Direttiva bassa tensione / Low Voltage Directive
2011/65/EU - 2015/863/EU	RoHS / RoHS

Norme armonizzate applicate o riferimento a specifiche tecniche:
Applied harmonized standards or mentioned technical specifications:

Norme armonizzate / Harmonized standards	
EN 61010-1:2010	Requisiti di sicurezza elettrica / Electrical safety requirements
EN 61326-1:2013	Requisiti EMC / EMC requirements
EN 50581:2012	RoHS / RoHS

Il produttore è responsabile per la dichiarazione rilasciata da:
The manufacturer is responsible for the declaration released by:

Johannes Overhues

Amministratore delegato
Chief Executive Officer

Caselle di Selvazzano, 19/11/2019

Questa dichiarazione certifica l'accordo con la legislazione armonizzata menzionata, non costituisce tuttavia garanzia delle caratteristiche.

This declaration certifies the agreement with the harmonization legislation mentioned, contained however no warranty of characteristics.

WARRANTY

Delta OHM is required to respond to the "factory warranty" only in those cases provided by Legislative Decree 6 September 2005 - n. 206. Each instrument is sold after rigorous inspections; if any manufacturing defect is found, it is necessary to contact the distributor where the instrument was purchased from. During the warranty period (24 months from the date of invoice) any manufacturing defects found will be repaired free of charge. Misuse, wear, neglect, lack or inefficient maintenance as well as theft and damage during transport are excluded. Warranty does not apply if changes, tampering or unauthorized repairs are made on the product. Solutions, probes, electrodes and microphones are not guaranteed as the improper use, even for a few minutes, may cause irreparable damages.

Delta OHM repairs the products that show defects of construction in accordance with the terms and conditions of warranty included in the manual of the product. For any dispute, the competent court is the Court of Padua. The Italian law and the "Convention on Contracts for the International Sales of Goods" apply.

TECHNICAL INFORMATION

The quality level of our instruments is the result of the continuous product development. This may lead to differences between the information reported in the manual and the instrument you have purchased. In case of discrepancies and/or inconsistencies, please write to sales@deltaohm.com. Delta OHM reserves the right to change technical specifications and dimensions to fit the product requirements without prior notice.

DISPOSAL INFORMATION

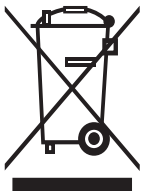

Electrical and electronic equipment marked with specific symbol in compliance with 2012/19/EU Directive must be disposed of separately from household waste. European users can hand them over to the dealer or to the manufacturer when purchasing a new electrical and electronic equipment, or to a WEEE collection point designated by local authorities. Illegal disposal is punished by law.

Disposing of electrical and electronic equipment separately from normal waste helps to preserve natural resources and allows materials to be recycled in an environmentally friendly way without risks to human health.



V1.6
07/2022